

SPECIFICATION

REV : XA

DATE : 15-AUG-2017

TITLE : LP12 series waterproof connector

	APPROVED	CHECKED	PREPARED
NAME	Ferry	Robin	William

- **Material Designation:** LP12 series waterproof connector



- **Materials Processes, Surface Treatment**

- **Contact**

Materials: Male Pin: Brass; Female Pin: Phosphor Bronze

Processes: Machining

Surface Treatment: Gold Plating for 4u" over nickel

- **Shell**

Materials: PBT

Processers: Injection

- **Insulator**

Materials :PBT

Processes: Injection

Color: Black

- **Material Introduction:**

- **Basic Information**

The performance of this connector is in conformity with Linko electric enterprise standard(in accordance with the TIA/EIA 568, MIL, IEC, CNS, etc.). the socket and adapter plug use spring snap lock for connection, convenient and reliable, shock resistance. The socket is mounted on the panel through the square flange, and the contact part shall be welded with the end of the conductor.

Offer standard insert arrangements from 2-8 pins.

- **Packing and Storage:**

The production are packed in plastic bag, The packing list must be set in every carton, which has been given clear information of material designation, part number, production order number, packet quantity and total product quantity. The packaged production should be stored in the

storeroom , in which Environment Temperature is $-40^{\circ}\text{C} \sim +80^{\circ}\text{C}$,Relative humidity $\leq 85\%$,no acidic, alkaline and other corrosive gases.

■ **Mating Type.**

Mated with: LP12 connector (male)

■ **Applicable Standards :** TIA/EIA 568、MIL、IEC、CNS Standards

■ **Process Requirements**

◆ **According to form of terminal**

The form of terminal is welding, the welding must be firm and cannot have pseudo soldering

◆ **According to form of mounting**

Please see the mounting hole figure.

PRODUCT CODE

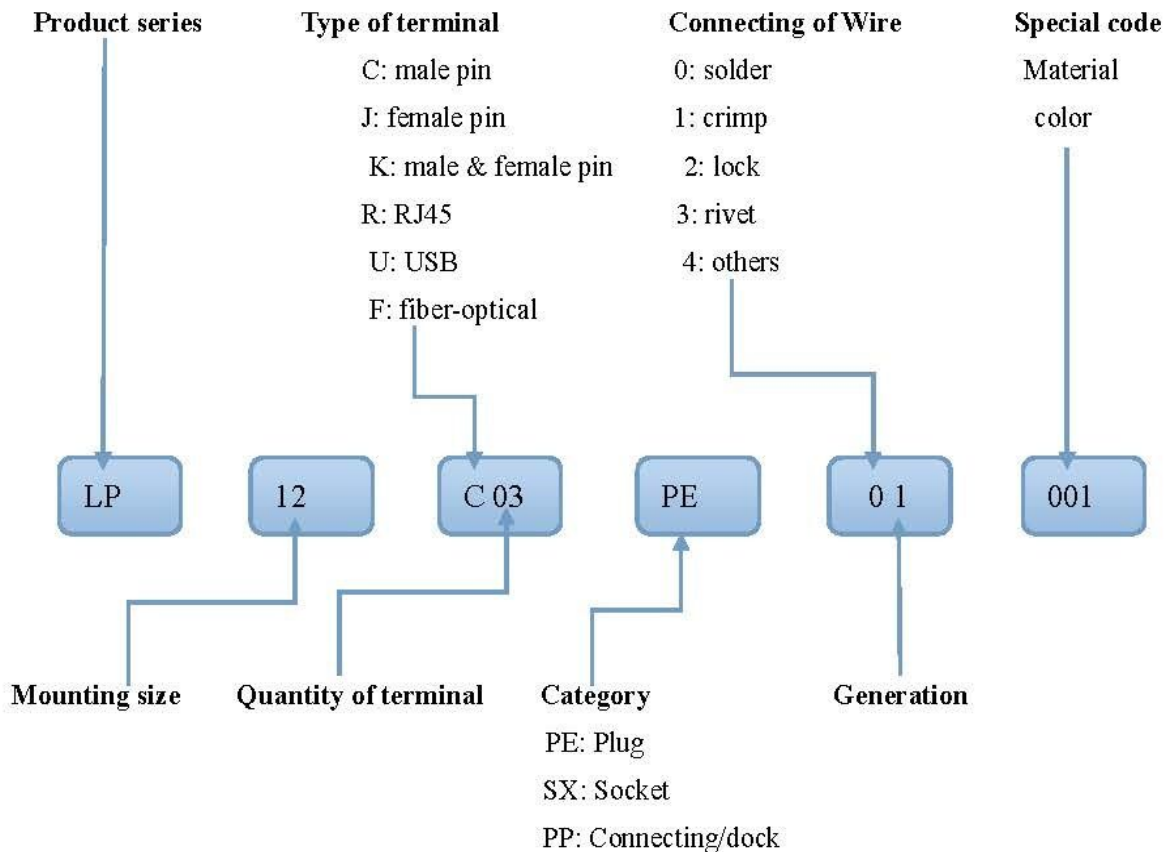

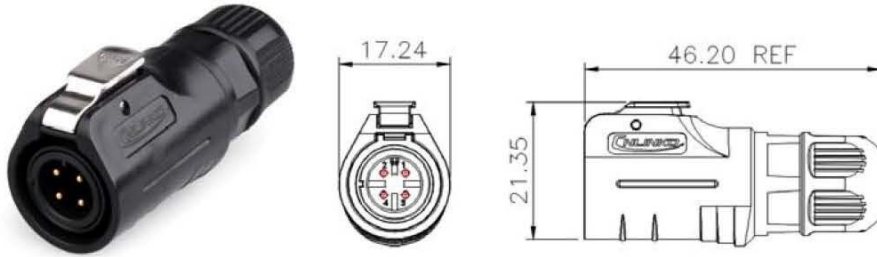

LP-12-C__PE-XX-001 Plug

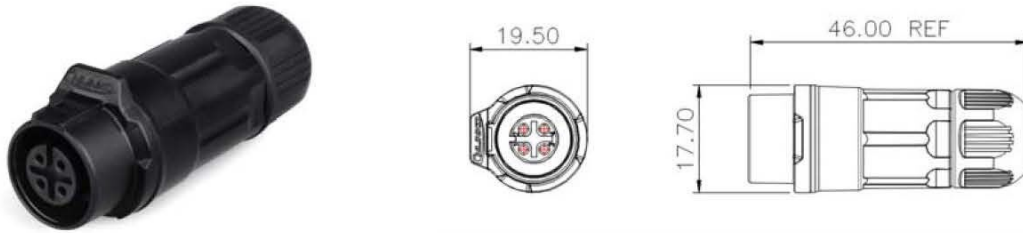

LP-12-J__PP-XX-001 Butt plug

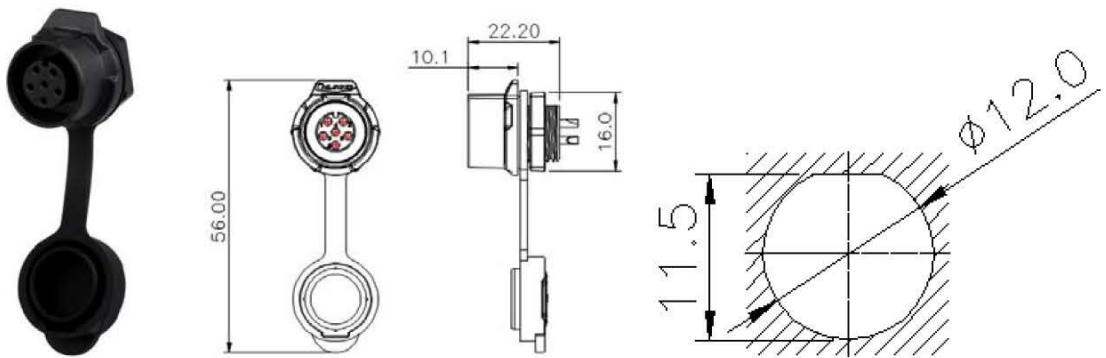

LP-12-J SX-XX-001 Single hole female socket

Mounting hole

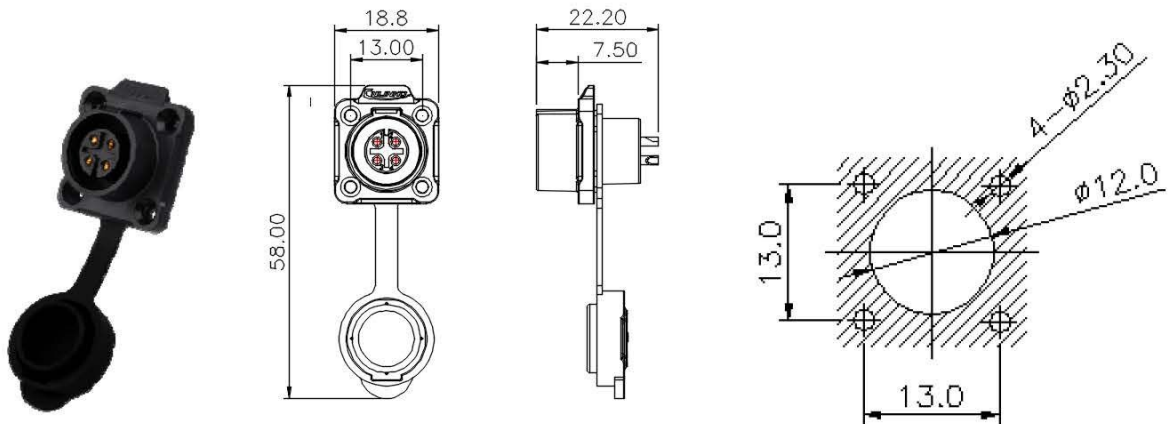

LP-12-J SX-XX-001 Four holes socket

Mounting hole

● **Product Characteristics Form**

SPECNO.:20170610	REV.: X A E C N NO. :	PAGE :	3/4
------------------	-----------------------	--------	-----

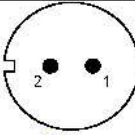
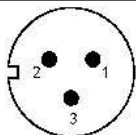
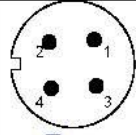
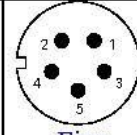
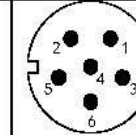
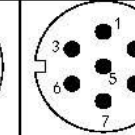
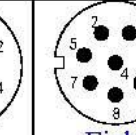
Number of pins	 Two pins	 Three pins	 Four pins	 Five pins	 Six pins	 Seven pins	 Eight pins	
Rated current	5A	5A	5A	5A	5A	3A	3A	
Operating voltage	125V	125V	125V	125V	125V	100V	100V	
Withstanding voltage	1500V	1500V	1500V	1500V	1500V	1000V	1000V	
Contact resistance	<5.0mΩ	<5.0mΩ	<5.0mΩ	<5.0mΩ	<5.0mΩ	<10.0mΩ	<10.0mΩ	
Temperature rise	5A 30°C ↓ ; 7A 40°C ↓ ; 10A 50°C ↓							
Contact dimension	Φ1.0*2	Φ1.0*3	Φ1.0*4	Φ1.0*5	Φ1.0*6	Φ0.8*7	Φ0.8*8	
Insertion and extraction force	0.6N Max.	0.9N Max.	1.2N Max.	1.5N Max.	1.8N Max.	2.1N Max.	2.4N Max.	
Mating cycle	1700 times							
Screw torque	42-53 (N.m) Torque wrench 200 (N.m)							
Temperature and humidity	-40°C ~ +80°C ; 40°C, 85%RH.							
Vibration	Frequency:5~200Hz, Amplitude:5mm, Speed :10m/s, No instantaneous short circuit in 0.10us.							
Impact resistance	294m/s ²							
Salt spray	PH6.5-7.2, NaCl, 5% 48H							
Wire specification	UL2464 24AWG*2C	UL2464 24AWG*3C	UL2464 24AWG*4C	UL2464 24AWG*5C	UL2464 24AWG*6C	UL2464 24AWG*7C	UL2464 24AWG*8C	
Applicable wire diameter	Scope of application (OD: Φ1-Φ6) mm , With waterproof ring (Φ6mm, Φ3mm)							
Protection level	IP67							
Certification standard	Comply with the TUV and UL certification standards							
SPECNO.:20170610			REV.: X A E C N NO. :			PAGE : 4/4		